

DRWG No

10-3194

THIRD ANGLE PROJECTION. DIMNS. IN MM

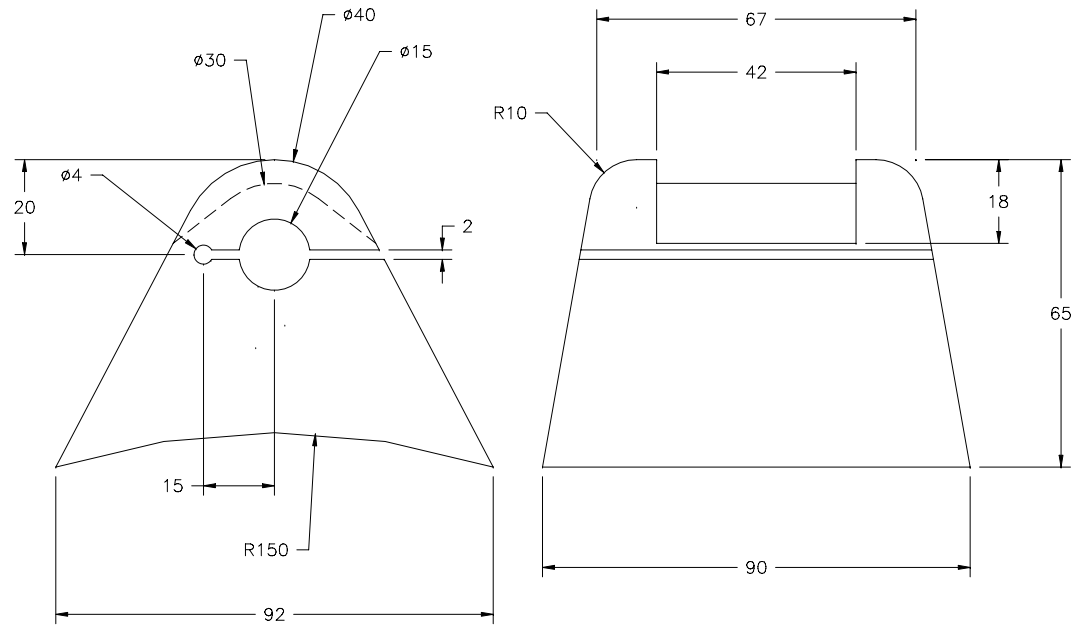

WEIGHT IN AIR 0.22kg
WEIGHT IN WATER 0.017kg

DATE 25Feb'03				CWA DESIGN COPYRIGHT NOT TO BE USED OR RE- PRODUCED WITHOUT EXPRESS PERMISSION FROM CWA	TOLERANCES :- UNLESS OTHERWISE STATED NO DEC PLACE ± 0.5 ANGULAR $\pm 1/4^\circ$ 1 DEC PLACE ± 0.3 2 DEC PLACE ± 0.15 HOLES UP TO 12.7mm $+0.10\text{mm} -0$ ALL COAXIAL DIAS CONCENTRIC WITHIN 0.05mm ALL HOLES ON PITCH CIRCLES WITHIN 0.10mm OF TRUE POS.	REMOVE ALL SHARP EDGES WITH 0.40 RAD OR CHAMFER UNLESS OTHERWISE STATED	MATERIAL	FINISH	SURFACE FINISH 0.8 UNLESS OTHERWISE STATED
DRAWN fjj							CWA100 POLYURETHANE		
SCALE NTS	4 Mar'03		2				DRWG No.	10-3194	
CHECKED	25Feb'03		1				TITLE	$\phi 300/15$ SADDLE CLAMP	
	DATE	C.NOTE	ISS	CWA PRODUCTS LIMITED HOOK BASINGSTOKE HANTS					