

DRWG No
10-3092

THIRD ANGLE PROJECTION. DIMNS. IN MM

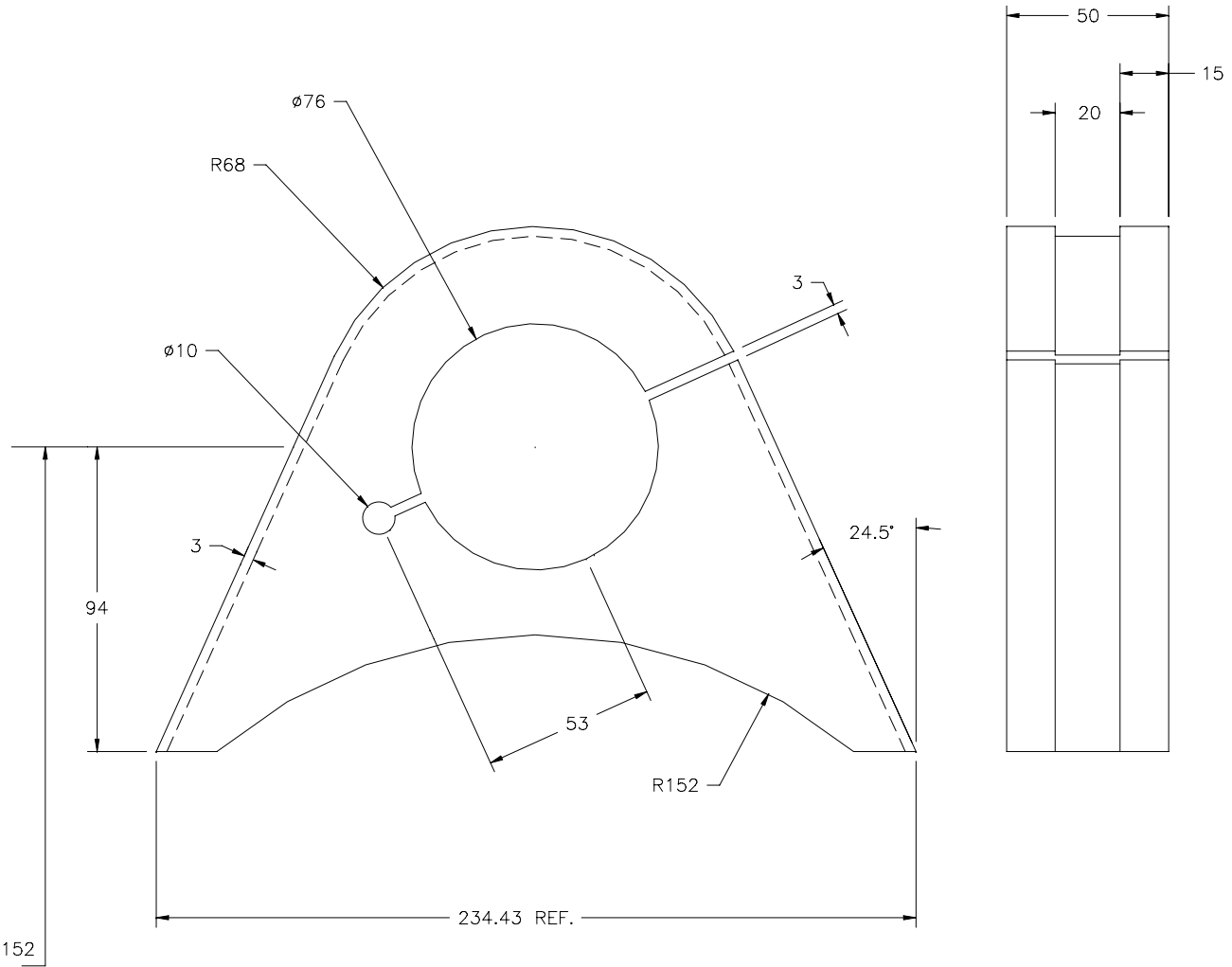

STRAP LENGTH 1138 EXACT

DATE 12Mar'02				CWA DESIGN COPYRIGHT NOT TO BE USED OR RE- PRODUCED WITHOUT EXPRESS PERMISSION FROM CWA	TOLERANCES :- UNLESS OTHERWISE STATED NO DEC PLACE ±0.5 ANGULAR ±1/4° 1 DEG PLACE ±0.3 2 DEC PLACE ±0.15 HOLES UP TO 12.7mm +0.10mm -0 ALL COAXIAL DIAS CONCENTRIC WITHIN 0.05mm ALL HOLES ON PITCH CIRCLES WITHIN 0.10mm OF TRUE POS.	REMOVE ALL SHARP EDGES WITH 0.40 RAD OR CHAMFER UNLESS OTHERWISE STATED	MATERIAL	FINISH	SURFACE FINISH 0.8 UNLESS OTHERWISE STATED
DRAWN fjj							CWA100 POLYURETHANE	DRWG No. 10-3092	
SCALE NTS	12Mar'02		1	CWA PRODUCTS LIMITED HOOK BASINGSTOKE HANTS			TITLE	SADDLE CLAMP	
CHECKED	DATE	C.NOTE	ISS						